

## Robot Base

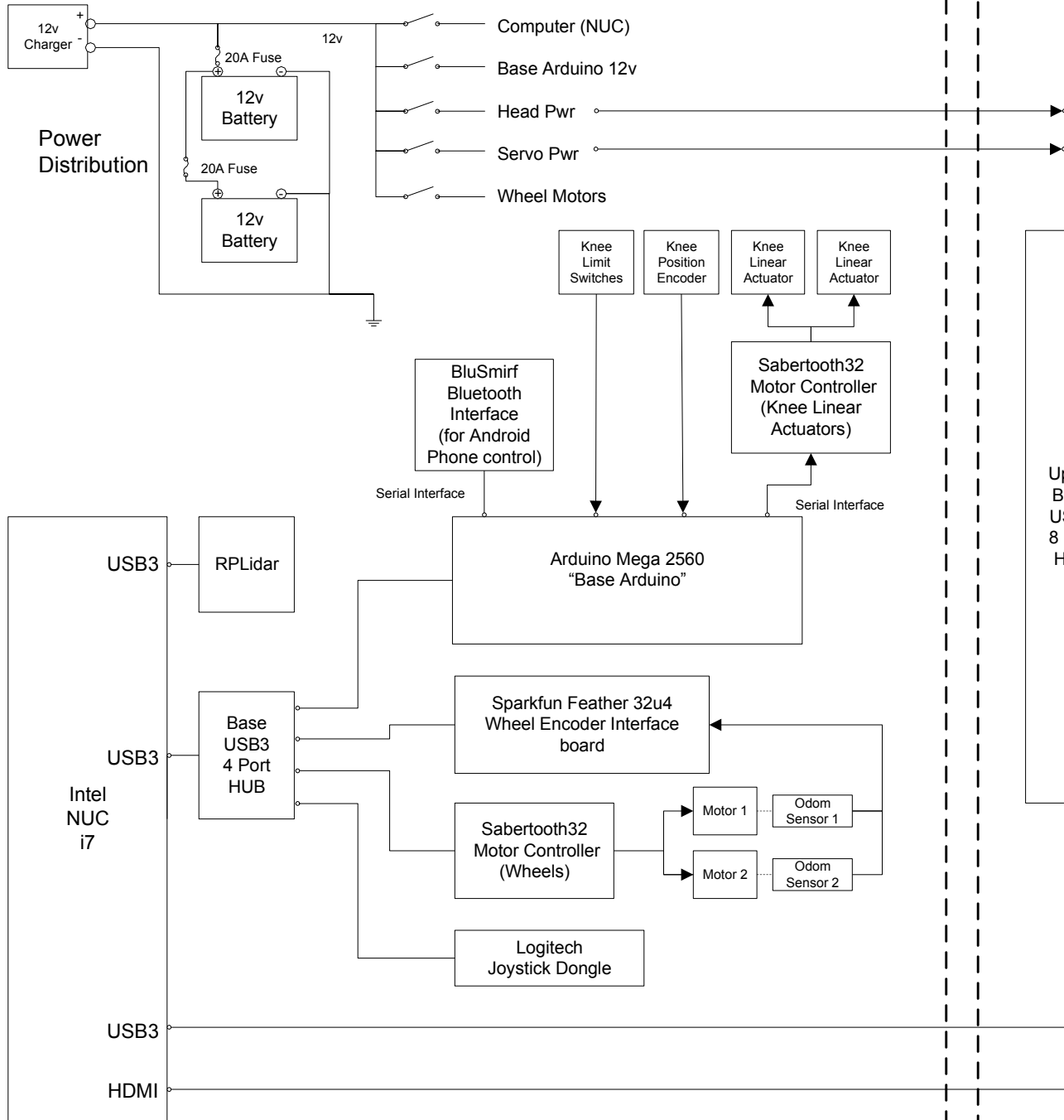

## Robot Body

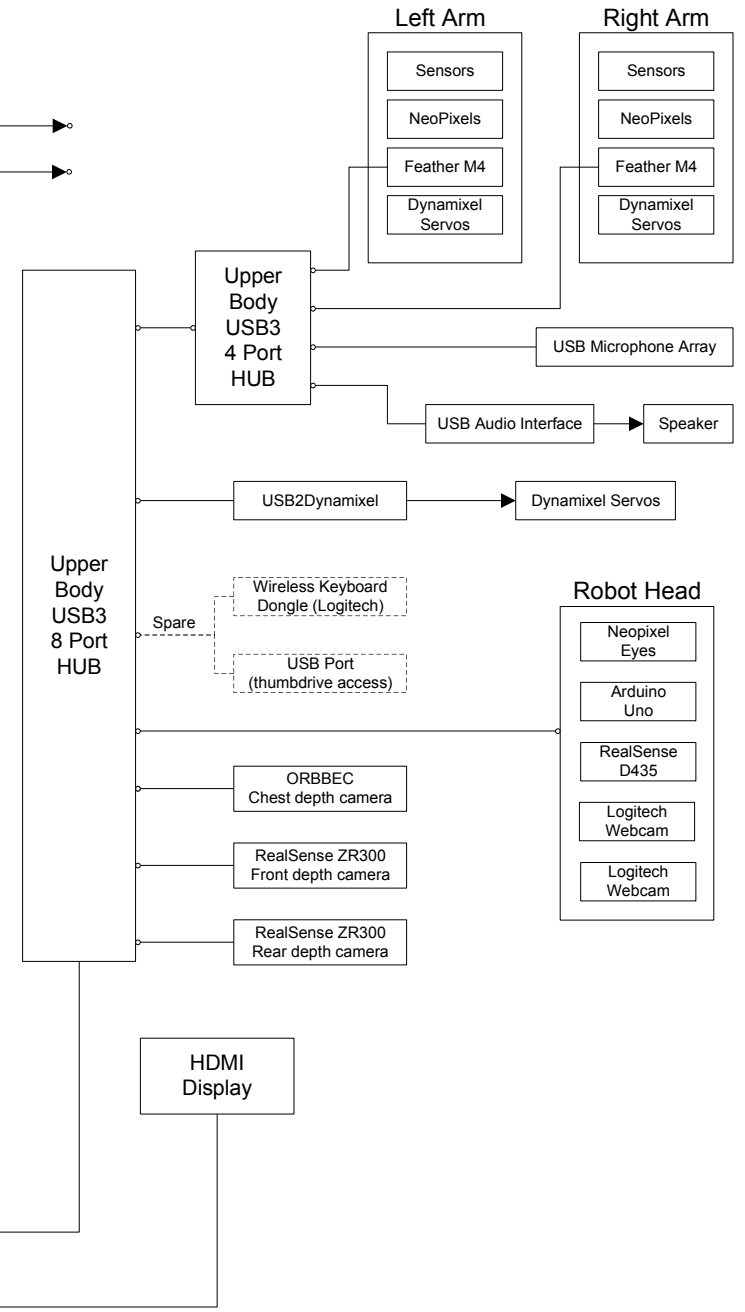

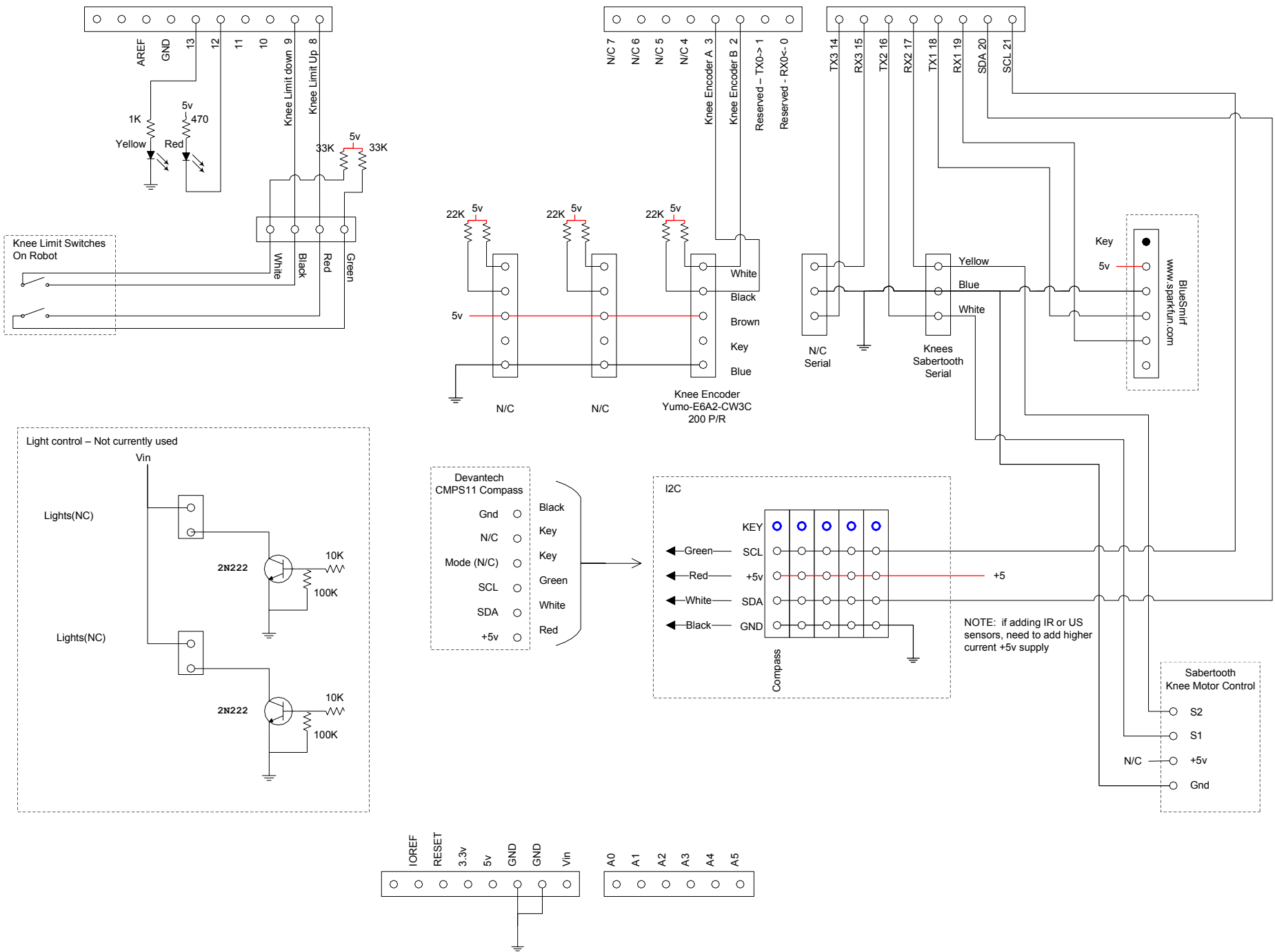

Sheldon Base Arduino Mega 2560 Interface Board

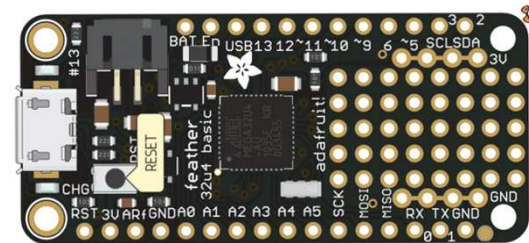
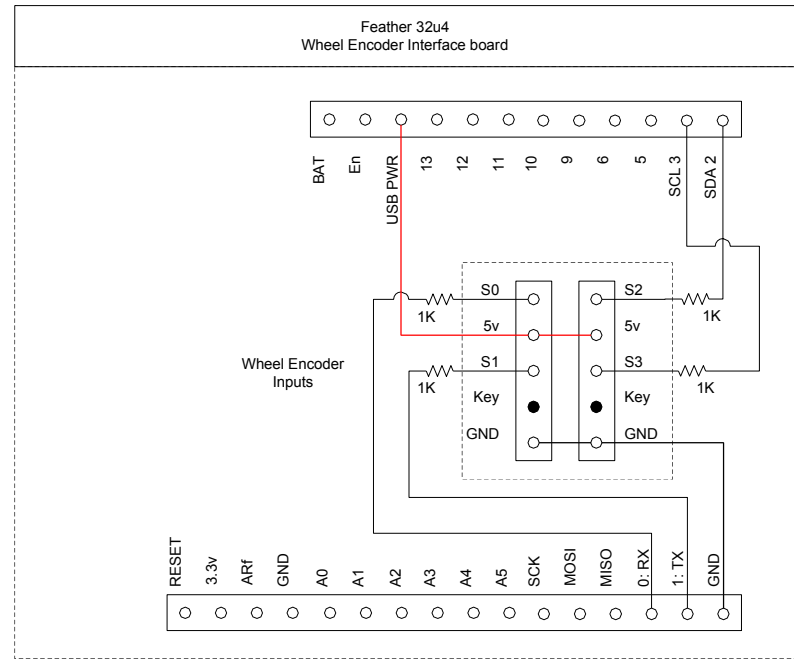
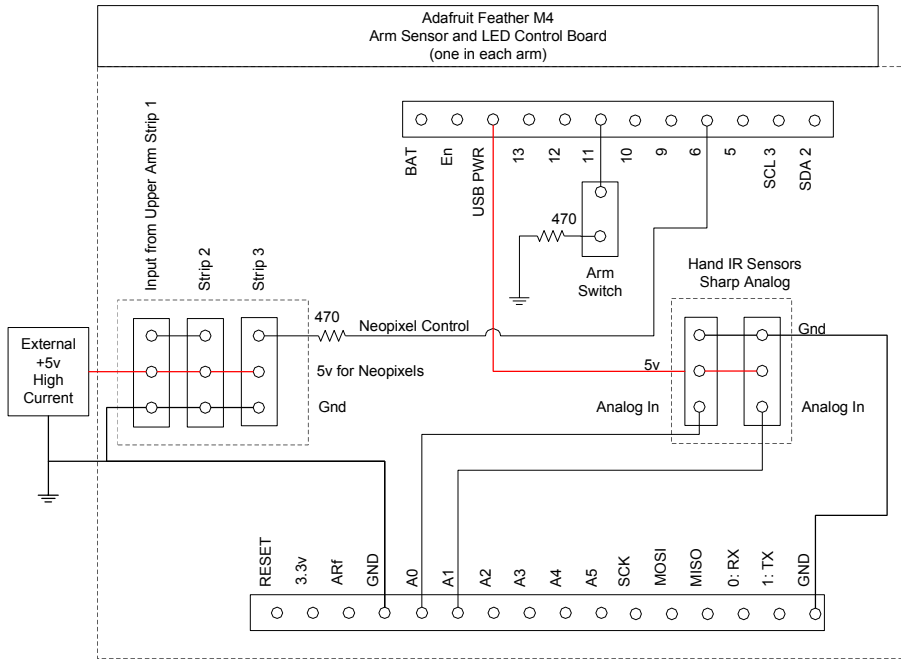

Dynamixel Servo Connection

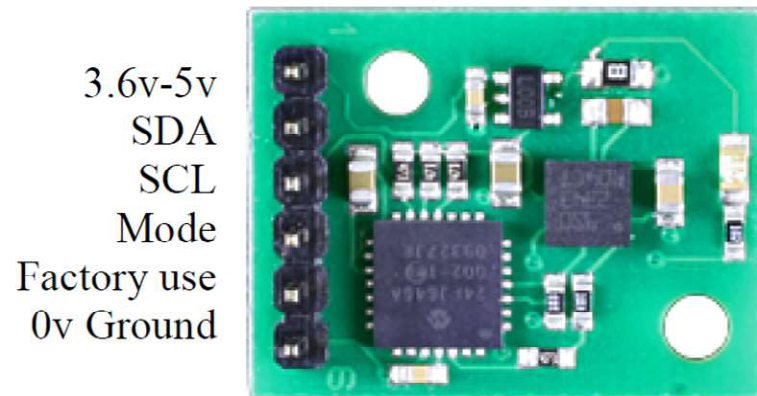
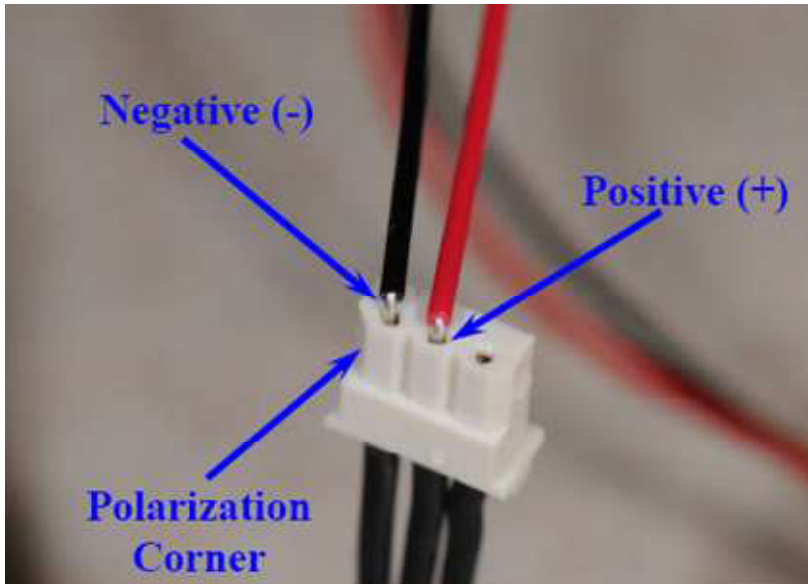

To enter the I2C mode of operation leave the mode pin unconnected